



Series
DSX

SIZE 9 CONCENTRIC TWINAX PIN CONTACT
FOR MILC17/17600002 CABLE
/

Issue:
MAY 04.01

Page
1 / 1

OUTER AND INTERMEDIATE CONTACT SUB-ASSEMBLY

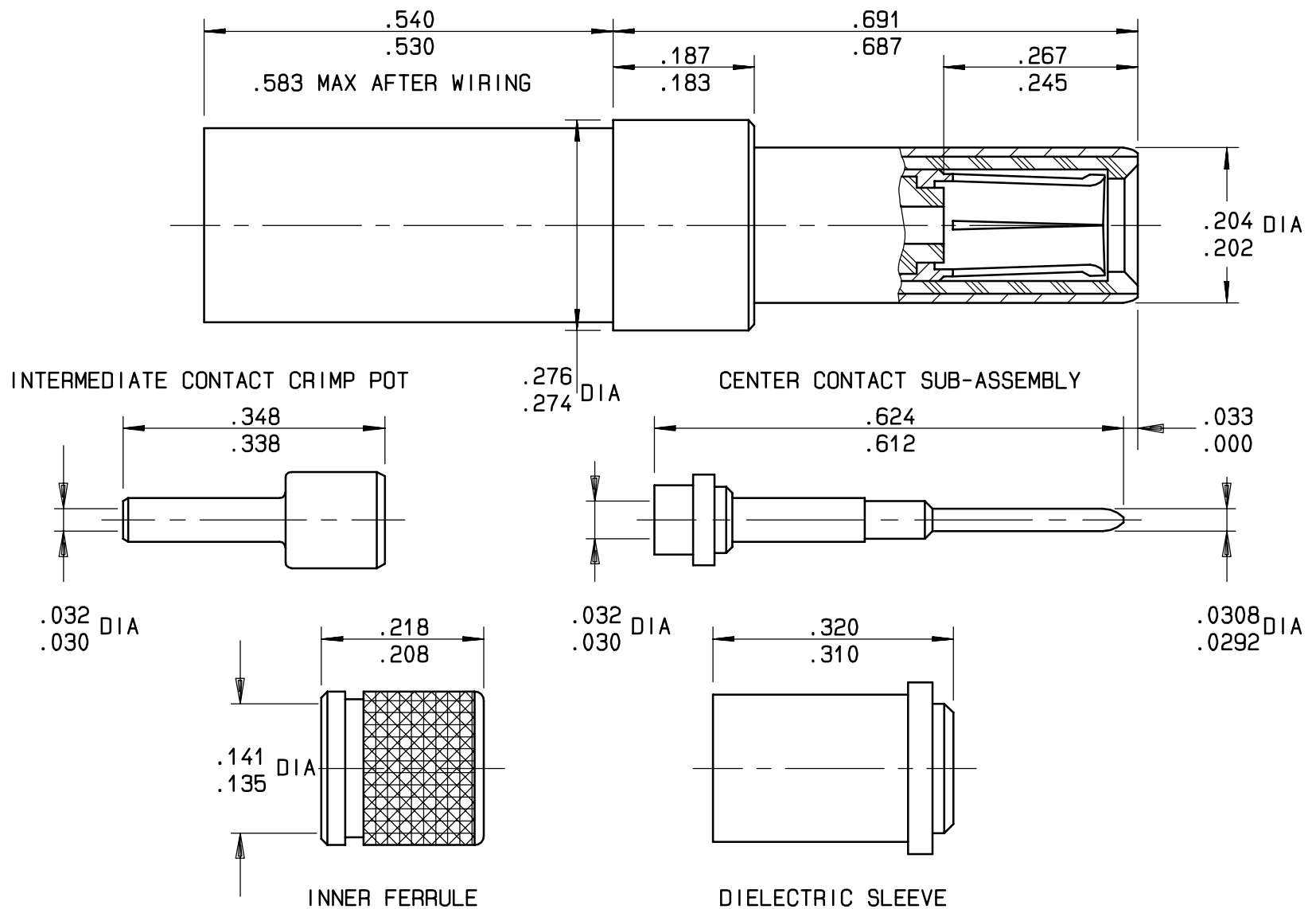

MATERIAL AND FINISH

ALL METAL PARTS: COPPER ALLOY_GOLD OVER NICKEL
DIELECTRIC PARTS: TEFLON
SEALING BUSHING: NYLON
SEALING SLEEVE: ELASTOMER SILICONE

TOOLS

CENTER CONTACT: CRIMPING TOOL M22520/2_01 (RADIALL P/N 282281)
SELECTOR SET: 5
POSITIONER: RADIALL P/N 282576
INTERMEDIATE CONTACT CRIMP POT: CRIMPING TOOL M22520/2_01 (RADIALL P/N 282281)
SELECTOR SET: 5
POSITIONER: RADIALL P/N 282574
OUTER CONTACT: CRIMPING TOOL M22520/5_01 (RADIALL P/N 282293)
DIE M22520/5_45 (RADIALL P/N 282236) DIE CLOSURE B .218/FLATS
EXTRACTION TOOL M81969/28_01 (RADIALL P/N 282946)
WIRING SEE SPECIFICATION RP3364

This information is given as an indication. In the continual goal to improve our products, we reserve the right to make any modifications judged necessary.

4112-9610

CREATION
PEN: /
NOM: JP MACARI
DATE: MAY29.91	MAY 04 01	DRAWING VISONEAL	.	.
APPR.: G CARTESSE	Issue	WIRING SEE SPEC RP3364 WAS RP5038	GOMBERT	.
		Revisions	Name	Approved